

General Safety Information

WARNING

- The WH-M778 front hub is not designed for downhill bicycle riding and off-road bicycle riding. However, depending on the riding condition, The hub axle could develop a crack, which may result in failure of the hub axle. This can lead to an accident that could result in serious injury or even death. Before riding, you should carefully check your hubs to make sure that there are no cracks in the axles, and if you find any sign of a crack or any other unusual condition, do NOT use the bicycle.
- The securing method and tightening torque for the front wheel both vary depending on the type of front suspension fork being used. When installing the front wheel to the front suspension fork, always be sure to follow the directions given in the Service Instructions for the front suspension fork. If the directions are not followed, the front wheel may fall out of the front suspension fork and serious injury may result.
- Check that the wheels are fastened securely before riding the bicycle. If the wheels are loose in any way, they may come off the bicycle and serious injury may result.
- The wheel is designed for cross-country riding. Do not use it for downhill riding, otherwise the wheel may become bent or otherwise damaged, and accidents may occur as a result.
- If the axle release lever is not used correctly, the wheel may come off the bicycle and serious injury could result.
- If the axle release lever is on the same side as the rotor, there is the danger that it may interfere with the rotor, so check that it does not interfere.
- These wheels are designed exclusively for use with disc brakes. Do not use these wheels with rim brakes.
- Be sure to carefully read the Service Instructions for the disc brakes also.
- Obtain and read the service instructions carefully prior to installing the parts. Loose, worn or damaged parts may cause the bicycle to fall over and serious injury may occur as a result. We strongly recommend only using genuine Shimano replacement parts.
- Read these Technical Service Instructions carefully, and keep them in a safe place for later reference.

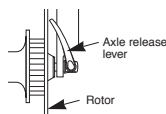

CAUTION

- Do not use rim tape. Rim tape may make it difficult to remove and install the tire, and the tire or tube may become damaged or the tires may suddenly puncture and come off, and severe injury may result.

CAUTION

- Use genuine Shimano spokes, nuts, plugs and washers, otherwise damage to the rim and hub unit may result.
- The air pressure should be within the range of 200-400 kPa {29-58 psi}.
- Be careful not to overtighten the plugs when adjusting the spoke tensions. If the plugs are overtightened, damage to the rim may result. (We recommend that you ask authorized bicycle dealers to make the adjustments.)
- We do not recommend that you use general-purpose alkaline puncture repair agents, as they may cause the rims to corrode and allow air leaks to occur.
- When using the special tool (TL-FC36) to remove and install the rotor mounting ring, be careful not to touch the outside of the rotor with your hands. Wear gloves to protect your hands from getting cut.

Note

- If the wheel becomes stiff and difficult to turn, you should lubricate it with grease.
- Do not apply any oil to the inside of the hub, otherwise the grease will come out.
- Special spoke wrenches are available as optional accessories.
- We recommend that you ask authorized bicycle dealers to adjust the spoke tensions if there is any initial play in the spokes and after the first 1,000 km of riding.
- Do not use detergents or chemical cleaners to wipe the wheel, otherwise they may cause the air sealant that has been applied to the joints in the rim to peel off.
- Do not use detergent or other chemicals when wiping the wheel, otherwise it may cause the sticker on the rim to peel off.
- Reflectors are also sold separately. Please ask your bicycle dealer for details.

Model number	Specification	Color
RR-550-WUW SW W/O BRACKET	JIS / CPSC	White
RR-550-WUA SW W/O BRACKET	AS	Amber
RR-317-WUA SW W/O BRACKET	DIN	Amber

- For maximum performance we highly recommend Shimano lubricants and maintenance products.
- Parts are not guaranteed against natural wear or deterioration resulting from normal use.

Replacing the spokes

- Pass the washer and plug over the spoke.
- After inserting the spoke into the hole in the hub flange, tighten the nut. When installing, use the spoke stopper to secure the spoke so that it does not turn, and then insert a screwdriver or similar tool into the groove in the nut to screw in the nut.
- Turn the plug clockwise to screw it into the screw hole in the rim. At this time, use the spoke stopper to stop the spoke from turning.

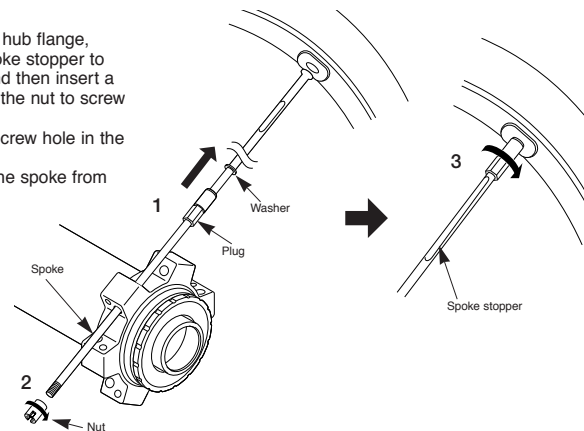

Note:

- If the washer is not installed, it will not be possible to adjust the spoke tension, so be sure to include the washer.
- Tighten the nut as far as the edges of the thread.

Spoke lacing

Lace the spokes as shown in the illustration.

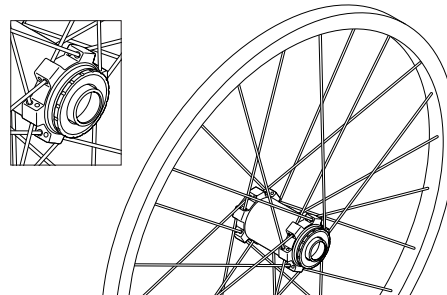

Spoke tension value	
Right side	Left side
600 - 1000 N (135 - 225 lbf)	900 - 1350 N (202 - 304 lbf)

* These values should be used as a guide only.

Maintenance

These units can be disassembled as shown in the illustrations. Grease should be applied to each part at periodic intervals.

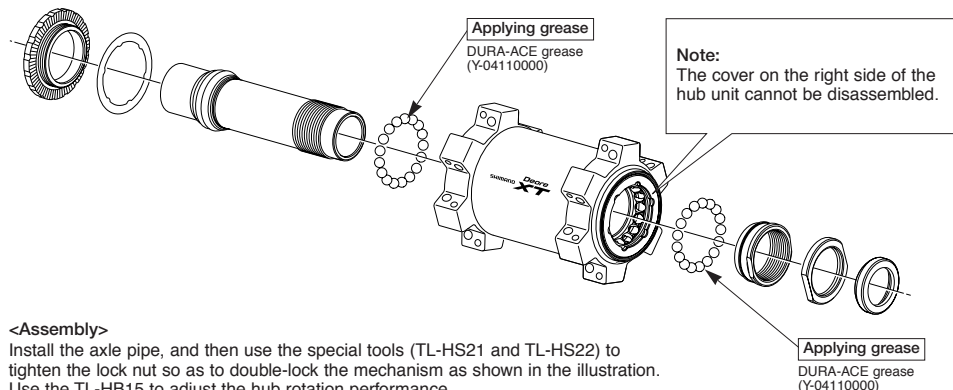

<Assembly>

Install the axle pipe, and then use the special tools (TL-HS21 and TL-HS22) to tighten the lock nut so as to double-lock the mechanism as shown in the illustration. Use the TL-HB15 to adjust the hub rotation performance.

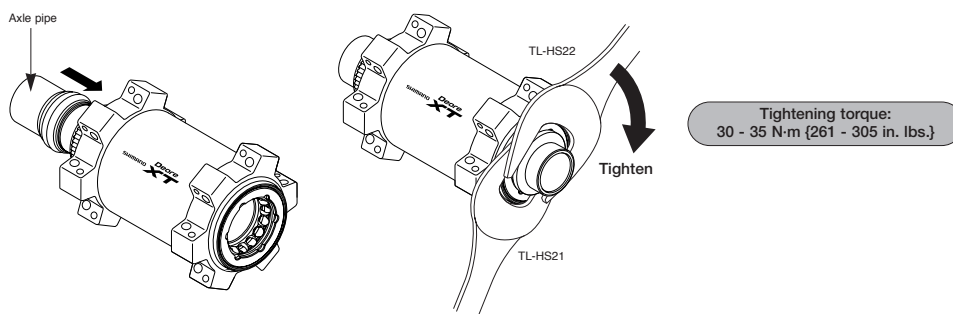

Installation of the rotor

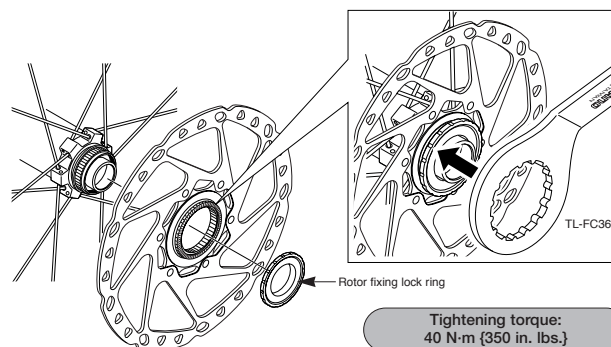

Technical Service Instructions

SI-4FE0A-002

WH-M778

Front Wheel

In order to realize the best performance, we recommend that the following combination be used.

Rotor	SM-RT78 / SM-RT97
-------	-------------------

Specifications

No. of spokes	24
Rim width	23.3 mm
Rim size	26"
Applicable tire size	26 x 1.5 ~ 2.25
Applicable brakes	Disc brake

SHIMANO

SHIMANO AMERICAN CORPORATION
One Holland, Irvine, California 92618, U.S.A. Phone: +1-949-951-5003

SHIMANO EUROPE B.V.
Industrieweg 24, 8071 CT Nunspeet, The Netherlands Phone: +31-341-272222

SHIMANO INC.
3-77 Oimatsu-cho, Sakai-shi, Osaka 590-8577, Japan

Please note: specifications are subject to change for improvement without notice. (English) © Jun. 2008 by Shimano Inc. XBC IZM Printed in Malaysia.